



AGA

Total Control

Redefining a British icon

Welcome to Total Control

The new AGA Total Control is the next generation AGA heat-storage cooker, the result of many years of research. With its simple to use touch-screen panel, you can choose which part of the cooker is on. You can heat each oven and hotplate separately. And – for the first time ever – here is an AGA cooker you can switch on and off as you please.

Design excellence and two generations of technology work in perfect harmony to create an AGA cooker for today and tomorrow. Extensive development and a dedicated manufacturing facility ensure the very highest levels of reliability.

Everything we have learned has led us here. AGA Total Control is the cooker you've been waiting for.







Why it's time for
AGA TOTAL CONTROL

total flexibility
great food
ambient warmth
design icon
economical to run



It's the AGA cooker for all seasons

The AGA Total Control cooker has the same cast-iron good looks for which the classic AGA heat-storage cooker is famous.

Cooking on the AGA Total Control cooker is a pleasure and produces amazing results. Its cast-iron ovens are gentle on food and lock in moisture, flavour, texture and, importantly, goodness – meaning the food you serve tastes delicious. Put simply, the AGA Total Control treats food as it should be treated – ensuring that you get the very best out of your ingredients.

From the exterior, the AGA Total Control appears to be just the same as the AGA cooker we know and love.

But open the door to the touch-screen control panel and it's a whole new picture...

State-of-the-art technology changes everything. It enables you to programme your AGA cooker to be on when you want to cook. Or off when you don't. Each hotplate and oven operates independently.

You can still enjoy that indefinable ambient AGA warmth while managing the amount of energy used. And in the summer months, you can choose to turn the AGA cooker off when it's not needed.

From weekdays to high days and holidays – whatever the season – you can tailor your AGA Total Control to suit you and your family's lifestyle.

time for AGA Total Control

It's the AGA cooker for all times

AGA Total Control enables you to use a 'different' AGA every day. You can choose to use it like a classic AGA heat-storage cooker with all ovens and hotplates on – or simply use a single hotplate or oven.

With our increasingly busy lifestyles – and the natural changes in routine over time – AGA Total Control fits in seamlessly with how you live your life, offering ultimate flexibility and convenience.

Thanks to the easy-to-use touch-screen panel, there is a setting for every family's need or occasion – available on demand at the touch of a button.

The ovens can be programmed to be ready to make breakfast when you come down in the morning and be set to go off as you close the front door. They can be programmed to be ready if there are children coming in from school or for when you come in from work. They can be ready for supper and stay on until it's time to turn in.

AGA Total Control is the AGA cooker for all times, providing all the benefits of 'kind-to-food' cast-iron cooking combined with technology that has created an AGA cooker perfectly in tune with your family's way of living...







How it all

WORKS

...beautifully

Control at the touch of a button

At the heart of the electric AGA Total Control cooker is a touch-screen control panel which puts you in charge of how and when the cooker is used. Discreetly housed behind the top left door, the nerve centre of the AGA Total Control cooker can be accessed directly or programmed via a remote control handset.

Using the control panel, the hotplates and ovens can be turned on manually when needed. It's so flexible – you can heat only one hotplate or both. You can opt to heat only the roasting oven, the baking oven or the simmering oven – or all three.

...but the touch-screen panel does so much more

Alternatively using the remote control handset, you can even programme the cast-iron ovens to come on automatically for one or two cooking cycles per day, seven days a week.

You can set the AGA Total Control cooker to provide the constant ambient warmth to the kitchen for which the AGA cooker is renowned.

Automatically ready

Manual (you choose)

Each zone (an oven or a hotplate) can be operated individually in manual mode. Any zone selected will remain on until switched off.

Slumber (ovens only)

In this mode all three ovens are active, pre-set at a simmering heat. Slumber setting is ideal for slow cooking and giving a gentle heat into the kitchen, creating that unmistakable ambient AGA warmth. When the ovens are in slumber mode, they take less time to reach full heat.

Auto (ovens only)

Selecting the auto function brings selected ovens up to full heat from off automatically when a programme is set. The ovens can be selected to operate once or twice each day, with the start and finish time of the 'cooking cycles' set by the user.

Auto slumber (ovens only)

Choosing this setting automatically brings the ovens up to full heat from slumber mode.



The hotplates

Each of the hotplates on the AGA Total Control cooker – the boiling plate and simmering plate – can be turned on or off independently as required simply by pressing the appropriate button on the control panel. Both hotplates are operated manually.

There are other innovations too. The patented engineering technology behind AGA Total Control means each hotplate is independently heated by its own element. This means constant heat when the hotplate is on. This also means that using the hotplates does not affect the heat in the ovens, as each zone is independently heated.

Boiling plate

The boiling plate is on the left-hand side. It is the hotter of the two hotplates. From cold, the boiling plate takes approximately 11 minutes to reach its operating temperature.

Simmering plate

The simmering plate is on the right-hand side. It is the cooler of the two hotplates. From a cold start, the simmering plate will achieve its operating temperature in about 8 minutes.



The ovens

The AGA Total Control cooker represents an important breakthrough in heat-storage engineering. Patented technology developed within our own research and development facility means that, for the first time, each oven has its own heat source. The result is increased programmability, more even heat distribution and more consistent oven temperatures.

What hasn't changed is that this next generation AGA cooker still works on the principle of radiant kind-to-food heat, meaning that – just like classic AGA heat-storage cookers – it cooks beautifully, locking in flavour and moisture.

This is the first AGA cooker to be part-assembled on a production line, meaning exceptional build quality and adherence to the highest production standards. Rest assured, however, that our skilled engineers finish the assembly in your home, maintaining our commitment to the very highest levels of customer care.



Powered oven venting

The AGA Total Control features an oven vent fan used when you are cooking in the roasting, simmering or baking oven to take cooking odours and grease vapours directly outside the house.

*Each oven has its own heat source,
meaning consistent oven temperatures*



Simmering oven

The AGA Total Control simmering oven is ideal for slow cooking, allowing flavours to develop and making even the toughest meats tender. Its large capacity allows several pans to be stacked and a number of dishes to be cooked simultaneously. From a cold start, the simmering oven takes around 45 minutes to reach its operating temperature. From the slumber setting, heat-up time is unchanged.



Baking oven

A moderate oven for baking cakes and biscuits, cooking fish, lasagne or a shepherd's pie, the AGA Total Control baking oven is truly flexible. And cooking sweet and savoury dishes together is no problem as the flavours do not mix. From a cold start, the baking oven takes around 22 minutes to reach its operating temperature. From the slumber setting, this is reduced to approximately 15 minutes.



Roasting oven

The roasting oven on the AGA Total Control grills, roasts and bakes bread beautifully. But new technology means it is possible to use only the roasting oven or to use it alongside either or both of the other two ovens. From a cold start, the roasting oven takes around 35 minutes to reach its operating temperature. From the slumber setting, this is reduced to approximately 15 minutes.





It's a
DESIGN
icon



Lower-impact living



AGA Total Control enables you to be in charge of how and when the cooker is on. The very latest technology ensures unparalleled levels of convenience and greater control over the energy used. With AGA Total Control, energy consumption can be reduced dramatically, depending of course on how much of the time you choose to have it on.

The remote control handset that comes with the AGA Total Control cooker displays the time and date and shows which settings you have programmed in. Setting the stylish handset is simplicity itself, with eight easy-to-use push buttons and all the information you need shown via a backlit LCD screen.



90% of an AGA cooker is recyclable, and we have a recycling centre at our Coalbrookdale foundry in Shropshire. The AGA Total Control cooker can last a lifetime – just like the previous generation of AGA cookers before it.



Why AGA-cooked food tastes better

Ask any owner of an AGA heat-storage cooker and they'll tell you that their food really does taste better. Cooking on an AGA cooker feels intuitive and there's nothing this amazing cooker cannot do to perfection.

The cast-iron ovens of an AGA cooker are gentle on food and lock in moisture, flavour, texture and goodness, meaning the food you serve tastes delicious.

Heat within the ovens comes from all surfaces simultaneously, ensuring a kinder cooking process without the fierce, drying direct heat that is present in the elements or flames of other types of cooker.

Put simply, the AGA cooker treats food as it should be treated – meaning you get the very best out of your ingredients.

It's not just statement food that the AGA cooker is renowned for. It's just as kind to a 10-minute supper on a busy weekday evening. You'll never taste a better pizza, for example, and it cooks pasta, rice and stir-fries to perfection incredibly quickly.

Technical specifications – TC3

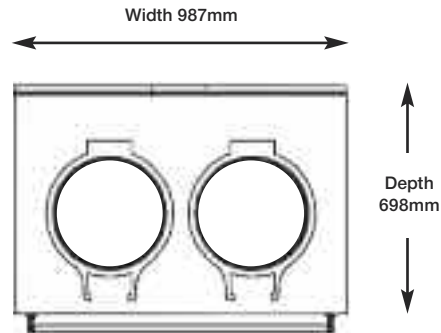
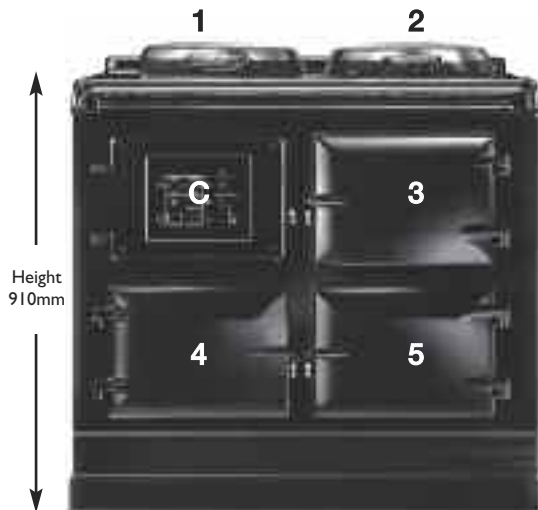

3 oven 30-amp electric AGA Total Control
approximate weight 370kg

- C. Control panel
- 1. Boiling plate
- 2. Simmering plate
- 3. Roasting oven
- 4. Baking oven
- 5. Simmering oven

	Height	Width	Depth
Oven dimensions	25.4cm	34.9cm	49.5cm

Quoted heat-up times are based on each zone of AGA Total Control being operated individually. If a large combination of zones is turned on simultaneously, this may slow down the individual heat-up times. If all zones are turned on at the same time it will take approximately one hour for the whole appliance to reach full operating temperature. All timings are based on the AGA benefiting from a single-phase electricity supply with a capacity of greater than 32 amps @ 230V. With other power supply configurations, times may change. In order to maintain warranty status, an interim service is due at 2½ years to check and change consumable items, including the vent fan, and to undertake a safety check. A full service is due at the end of year five. The appliance warranty does not cover commercial use (see separate warranty book for further details). Note: the plinth of AGA Total Control should not be tiled, as it needs to be accessible for maintenance

Dream in colour



Black



Pearl Ashes



Pewter

Standard colours



Cream



Blue



British Racing Green



Aubergine



White



Heather

Signature colours



Duck Egg Blue



Pistachio

Please note that while we take every care to ensure these colours are accurate, they are only as close as the printing process will allow. The unique enamelling process means that colours may darken when in use. Colour samples are available in AGA shops.

How to achieve Total Control

1

Expert advice

From the minute you decide you want to learn more about the AGA cooker to the moment your new model is delivered, our friendly and knowledgeable staff will be there to ensure the process is seamless. You can find details of your closest AGA shop at www.agaliving.com or by calling 0845 7125 207.

2

Free home survey

Every AGA installation starts with a free home survey. The team at your AGA shop will arrange – at a time that works for you – for one of our experienced Project Managers to visit you at home to discuss where you would like to site your AGA cooker.

3

Total peace of mind

The bespoke service continues once your AGA cooker is ready to be installed. To ensure the highest standards and complete peace of mind, every AGA Total Control is part factory-assembled and we have a dedicated team of qualified engineers to install your new AGA cooker in your home. Once we have installed your new AGA Total Control, we will validate your five-year parts and one-year labour warranty.



It's time for Total Control

It's time for an AGA

Simply call us on **0845 7125 207**

Republic of Ireland: 01 663 6166
International: +44 (0)115 946 6106

www.agaliving.com



search **AGA**



Total Control

Copyright © AGA Rangemaster Limited 2011. Brand names, words and logos are registered trademarks of AGA Rangemaster Group, Juno Drive, Leamington Spa, Warwickshire, CV31 3RG.

AGA is a trading name of AGA Rangemaster Limited. Registered in England & Wales under registered number 3872754. Registered office: Juno Drive, Leamington Spa, Warwickshire CV31 3RG England. Patent pending number 1008608.

Part of the
AGA RANGEMaster
Group

This information contained in this brochure is provided as a guide only, and should not be relied upon. For full technical and installation details, refer to the relevant Users and Installation Guide. Installation is subject to site survey. We reserve the right to change specifications without notice at any time.

